

DWG NO: 0097-0655	
REVISIONS	
WAS PHOTO ETCH PROCESS .700 MAT'L WIDTH WAS 8.0 9.45 WAS 8.02 ECN #8310 BMG 7-16-93 EWS 7-19-93	02
ECO-E4370 ADDED 2 PLCS TO R.035 DIMENSION. RKM 03/12/04 EWS 03/15/04	03
ECO-E4973 ADDED ±.045 TOL TO LENGTH RKM 03/31/05 EWS 03/31/05	04

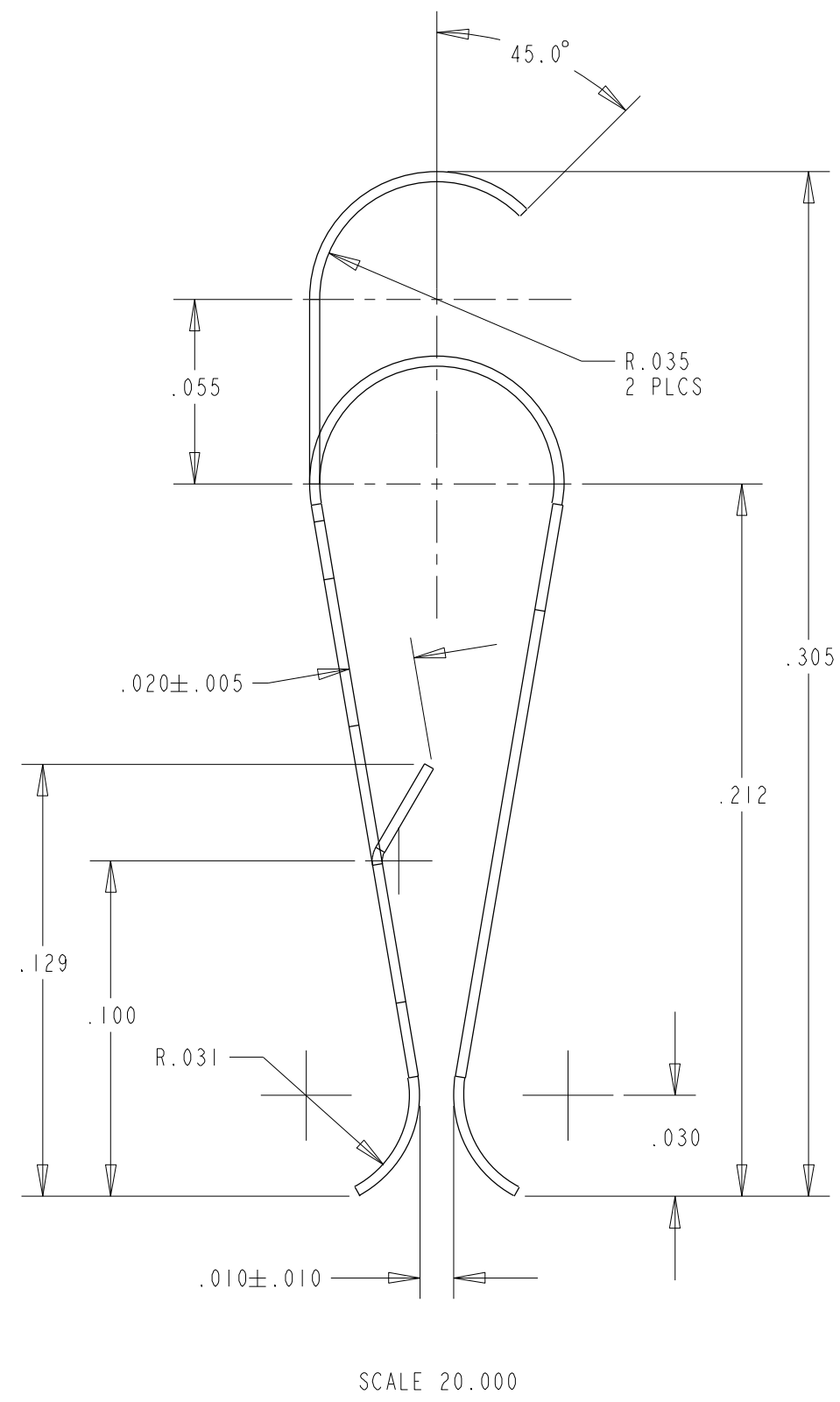
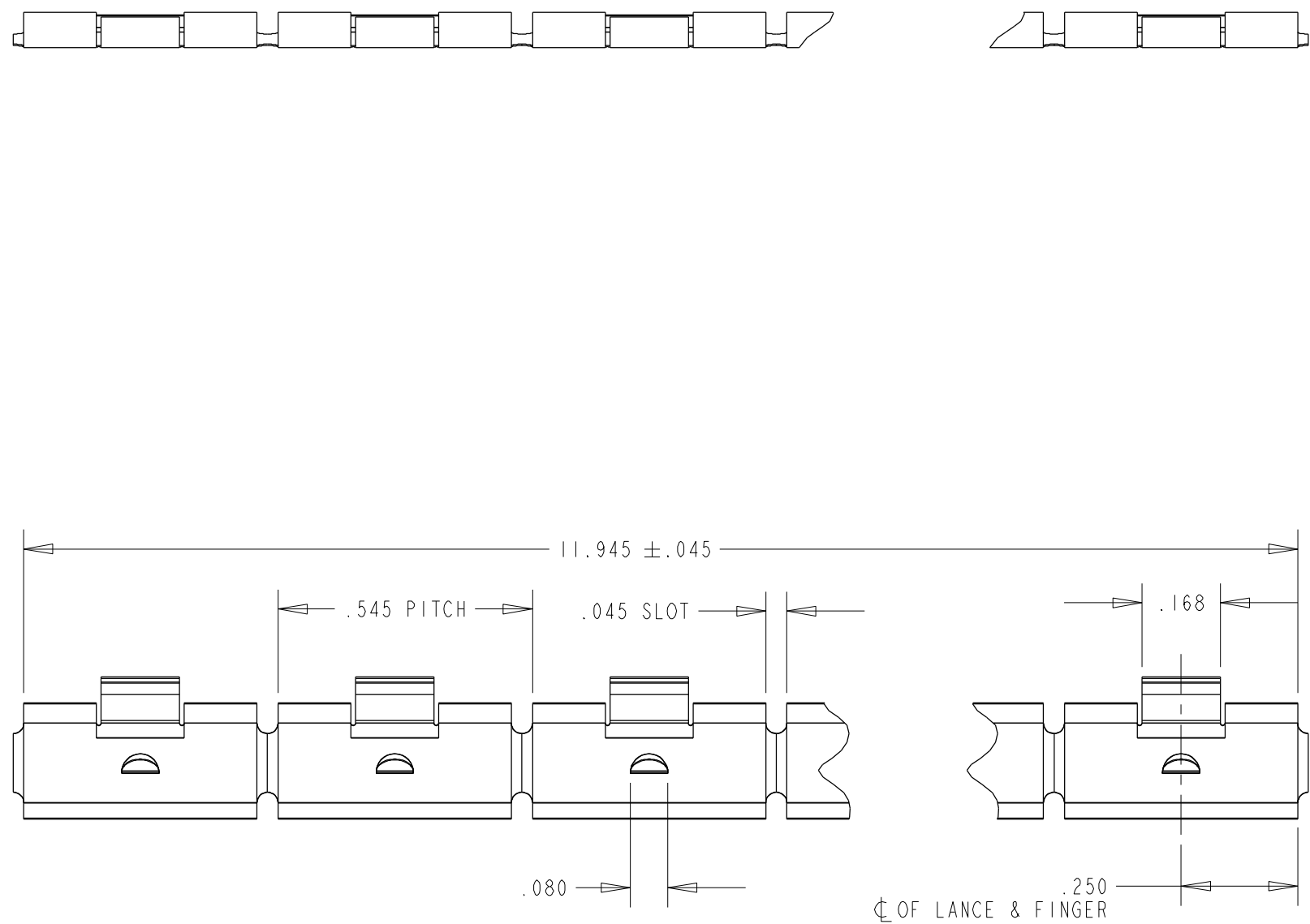

MAT'L CODE: C172002054

MATERIAL: .0035 ± .00015 X .700 ± .003 BE CU ALLOY 25 1/4 HARD ENDURANCE GRADE	TOLERANCES NOT SHOWN DECIMAL 2 PL'S ± .015 DECIMAL 3 PL'S ± .010	 DELAWARE WATER GAP PENNSYLVANIA	DRAWN BY: TWG	DATE: 4/6/93
HEAT TREAT: TO DPH 373 MIN USING A 500 GRAM LOAD	ANGULAR ± 3°		CHECKED: EWS	DATE: 4/13/93
THICKNESS AFTER CLEANING AND BEFORE PLATING .0025 ± .0002	THIRD ANGLE PROJECTION	PERPENDICULAR GROUNDING CONTACT		
FINISH: AS REQ'D	UNITS: INCH [MM] SCALE: 3.000	REF. DWG. NO. X	DWG. NO. 0097-0655	REV 04
CAD MAINTAINED DRAWING. MANUAL CHANGES UNAUTHORIZED.				

THIS INFORMATION IS CONFIDENTIAL AND PROPRIETARY TO LAIRD TECHNOLOGIES. IT MAY NOT BE DISCLOSED TO ANYONE, OTHER THAN LAIRD TECHNOLOGIES PERSONNEL, WITHOUT WRITTEN AUTHORIZATION FROM LAIRD TECHNOLOGIES.

DWG NO: 0097-0655

SHEET 1 OF 1