

## DISTINCTIVE CHARACTERISTICS

- High resolution of 64 x 32 pixels
- 64 colors of backlighting can be controlled dynamically
- Display with LCD, RGB LED backlighting
- General brightness of backlight is dynamically controlled in eight steps from dark to bright
- Operated by commands and data supplied via serial communications (SPI)
- Can display as many as four lines of text with ten characters each
- Incorporates bitmap display function
- Programmable display graphics for alphanumeric characters and animated sequences
- Dual image VRAM for quick change of displayed images
- Low energy consumption
- Dust tight construction

Viewing area: 13.9mm x 10.6mm (horizontal x vertical)

Bracket has crimped legs to ensure secure PC mounting and prevent dislodging during wave soldering



Actual Size

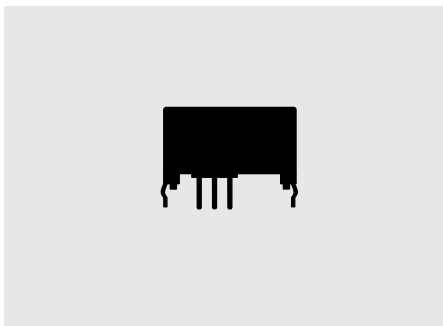

## DISPLAY DESCRIPTION

Terminals	LCD Mode	LED Color	LCD/LED
Straight PC	Black & White FSTN Positive	Red/Green/Blue	

## LCD SPECIFICATIONS

### Characteristics of Display

Display Operation Mode	FSTN positive; background colors, black & white
Display Condition	Transflective with built-in LED backlight
Viewing Angle Direction	6 o'clock
Viewing Area	13.9mm x 10.6mm (horizontal x vertical)
Pixel Format	64 x 32 pixels (horizontal x vertical)
Pixel Size	0.18mm x 0.24mm (horizontal x vertical)
*Operating Temperature Range	-15°C ~ +50°C (+5°F ~ +122°F)
Storage Temperature Range	-20°C ~ +60°C (-4°F ~ +140°F)
Backlight LED	RGB: red/green/blue

\* In a low temperature environment (below 0°C), speed and contrast decrease when image changes. The non-indicator dot may become dense in a high temperature environment (about +50°C).

### Absolute Maximum Ratings

Items	Symbols	Ratings
Supply Voltage	$V_{DD}$	-0.3V to +7.0V
Input Voltage	$V_I$	-0.3V to $V_{DD} + 0.3V$
Output Voltage	$V_O$	-0.3V to $V_{DD} + 0.3V$

### Optical Characteristics (Temperature at 25°C)

Items	Symbols	Min	Typical	Max
Contrast Ratio	Cr	—	3.0	—
Viewing Angle (Cr ≥ 1.1)	Up & Down	$\theta$	—	90°
	Right & Left	$\phi$	—	90°

### Recommended Operating Conditions

Items	Symbols	Minimum	Typical	Maximum
Supply Voltage	$V_{DD}$	4.9V	5.0V	5.1V
Input Voltage	$V_I$	0V	—	$V_{DD}$
SPI Clock Frequency	$f_{SCK}$	—	—	8MHz
Current Consumption	$I_{DD}$	** 10mA	—	*** 50mA

\*\* 10mA: Backlighting LED is off

\*\*\* 50mA: Backlighting LEDs (Red, Green, Blue) are maximum brightness

## BLOCK DIAGRAM & PIN CONFIGURATIONS

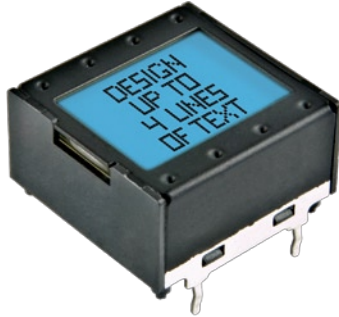

**High Resolution SMARTDISPLAY™**  
with RGB LED and  
Black and White LCD Mode

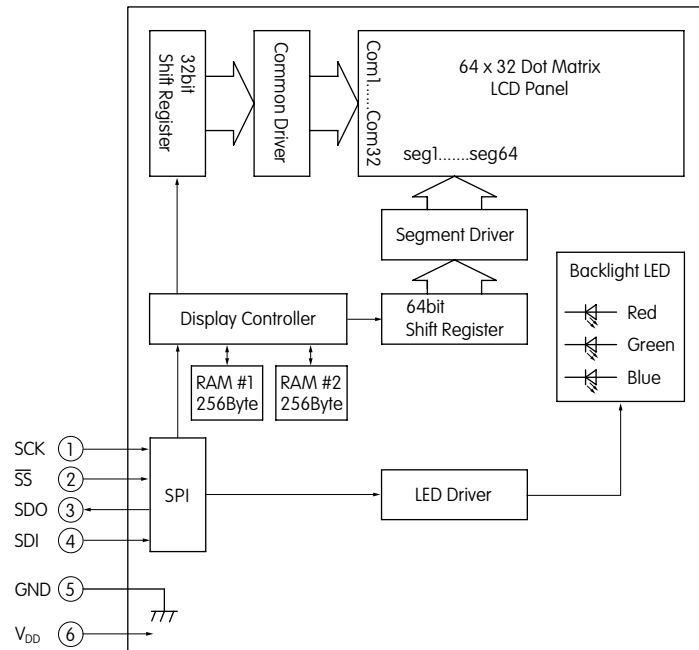

Pin No.	Symbol	Name	Function
①	SCK	Serial Clock	Clock line for SPI that synchronizes commands and data
②	$\overline{SS}$	Slave Select	Chip select for SPI; line is active low
③	SDO	Data Out	Data output line for SPI
④	SDI	Data In	Data input line for SPI
⑤	GND	Ground	
⑥	V <sub>DD</sub>	Power	Power source for logic circuit and LCD

## TYPICAL DISPLAY DIMENSIONS

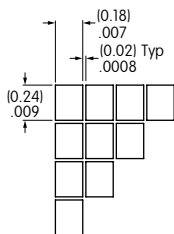
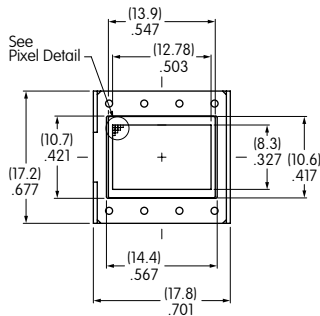

Pixel Detail

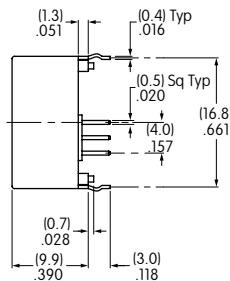

Terminal numbers are not on the device.

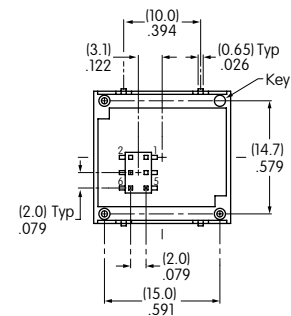

Footprint

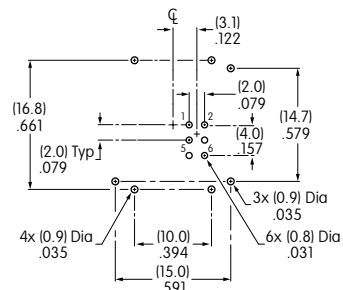

## TIMING SPECIFICATIONS

### SPI Characteristics (See Timing Diagram)

(Temperature at  $-15^{\circ}\text{C} \sim +50^{\circ}\text{C}$  and  $V_{\text{DD}} = 5.0\text{V} \pm 2\%$ )

Items	Symbols	Minimum	Maximum
SPI $\overline{\text{SS}}$ Set Up Time	$t_{\text{sSS}}$	10ns	
SPI $\overline{\text{SS}}$ Hold Time	$t_{\text{hSS}}$	10ns	
SPI_CLK Cycle	$t_{\text{cycCK}}$		8MHz
SPI_CLK Width	$t_{\text{hwCK}}$	10ns	
SPI_DI Set Up Time	$t_{\text{sDI}}$	10ns	
SPI_DI Hold Time	$t_{\text{hDI}}$	10ns	
SPI_DO Delay Time	$t_{\text{dDO}}$	10ns	

SPI Timing Chart ( $\overline{\text{SS}}$  Using)

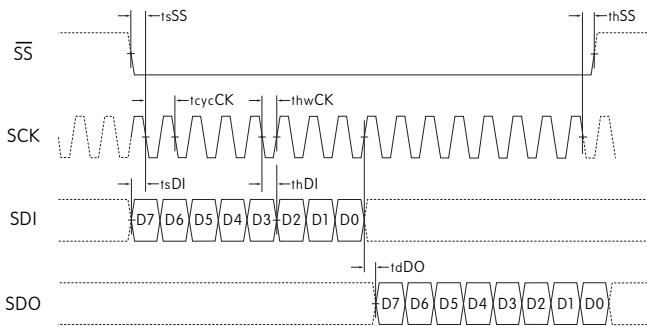

Circuit Example

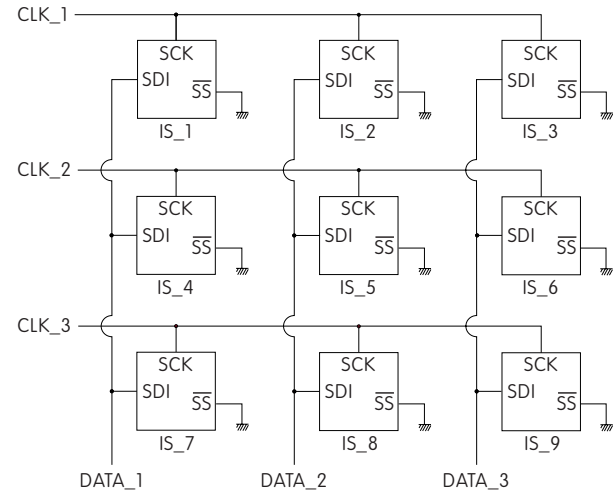

SPI Timing Chart ( $\overline{\text{SS}}$  Low Level Fixed)

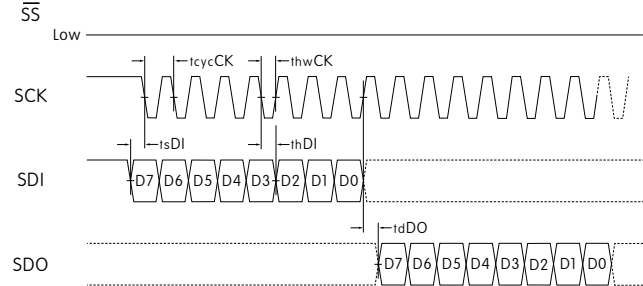

SDI and SCK shall be kept high when idle.

## BITMAP

Segment	1	2	3	4	5	6	7	8	9	...	16	...	49	...	56	57	58	59	60	61	62	63	64																	
Common	Byte8								Byte7								Byte2								Byte1															
COM1	D0	D1	D2	D3	D4	D5	D6	D7	D0	...	D7	...	D0	...	D7	D0	D1	D2	D3	D4	D5	D6	D7																	
COM2	Byte16																Byte9																							
	D0 D1 D2 D3 D4 D5 D6 D7								D0 D1 D2 D3 D4 D5 D6 D7								D0 D1 D2 D3 D4 D5 D6 D7																							
•	•								•								•																							
•	•								•								•																							
•	•								•								•																							
	Byte256																...								...								Byte249							
COM32	D0 D1 D2 D3 D4 D5 D6 D7								D0 D1 D2 D3 D4 D5 D6 D7								D0 D1 D2 D3 D4 D5 D6 D7																							

### Transferring Display Data/Displaying LCD Command and Data Sequence

Command	Data (256 Bytes)																																							
0 x 55	Byte1								Byte2								...								Byte255								Byte256							
0 1 0 1 0 1 0 1	D7	D6	D5	D4	D3	D2	D1	D0	D7	D6	...	D1	D0	D7	D6	D5	D4	D3	D2	D1	D0																			

**Notes:** Display RAM has two screen areas. The first area is for the display on current LCD; the second area is for the data to be displayed next. The screens are changed when the second area is fully stored.

## COMMANDS & DATA

- Transferring display data/displaying on LCD: command (1 Byte) + data (256 Bytes)
- Others: command (1 Byte) + data (1 Byte)
- Commands can be accepted only when all bits coincide; otherwise, they are not acknowledged
- Additional commands will not be received until the communication of commands (1 Byte) and data (256 or 1 Byte) is completed
- There is no time limit from the beginning to end of data receipt
- Commands may be executed consecutively (no need to wait between commands)
- Irregular commands or data are not recognized
- Initial status at power activation: LCD display off, LED off (brightness 1/20, color off)

### Transferring Display Data/Displaying on LCD

Command		Data	Remarks
Hex	Binary		
0 x 55	01010101	256 Bytes (64 x 32 = 2,048 bits)	See below for details of bitmap data

### LED (Backlight) Color Set

Command		Data	Remarks
Hex	Binary		
0 x 40	01000000	R R G G B B 1 1 2 bits x 3	For each of RGB: 00 = off            10 = 1/2 01 = 1/4           11 = full

### LED (Backlight) Brightness Set

Command		Data	Remarks
Hex	Binary		
0 x 41	01000001	* * * 1 1 1 1 1 3 bits	For leading 3bits: 000 = 1/20            100 = 1/3 (dark)                101 = 1/2 001 = 1/10           110 = 2/3 010 = 1/7            111 = full 011 = 1/5            (bright)

### Reset (Returning to Initial Status at Power Activation)

Command		Data	Remarks
Hex	Binary		
0 x 5E	01011110	0000011	Returning to initial status at power activation

## PRECAUTIONS FOR HANDLING & STORAGE OF LCD DEVICES



### Handling

1. The IS Series devices are electrostatic sensitive.
2. The IS series devices are not process sealed.
3. If the LCD is accidentally broken, avoid contact with the liquid and wash off any liquid spills to the skin or clothing.
4. Clean cap surface with dry cloth. If further cleaning is needed, wipe with dampened cloth using neutral cleanser and dry with clean cloth. Do not use organic solvent.
5. Recommended soldering time and temperature limits: 5 seconds maximum @ 270°C maximum
6. Do not exceed 60°C at the LCD level.

### Storage

1. Store in original container and away from direct sunlight.
2. Keep away from static electricity.
3. Avoid extreme temperatures, high humidity, gaseous substances, and all forms of chemical contamination.